

HIGH RIGIDITY STRIPPER GUIDE PINS

—STRIPPER PLATE FIXING TYPE—

STOPPERS FOR BALL CAGES, FIXED TYPE / CLAMPS FOR STRIPPER GUIDE PIN



SGP Stock

Printed in Red

SGPWS and SGPWH can be used with any bushings listed on pages 11 to 16. Select a suitable combination according to the nature of operation. The quantity discount rate is also applicable to alteration cost. All price & lead time are to be quoted.

The quantity discount rate is also applicable to alteration cost. All price & lead time are to be quoted.

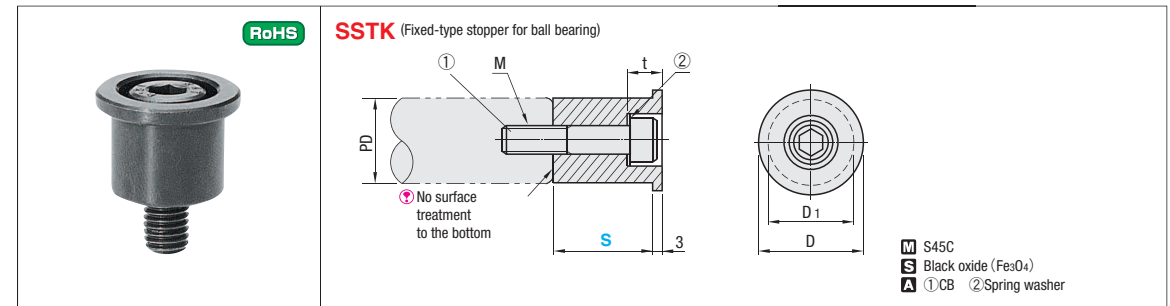
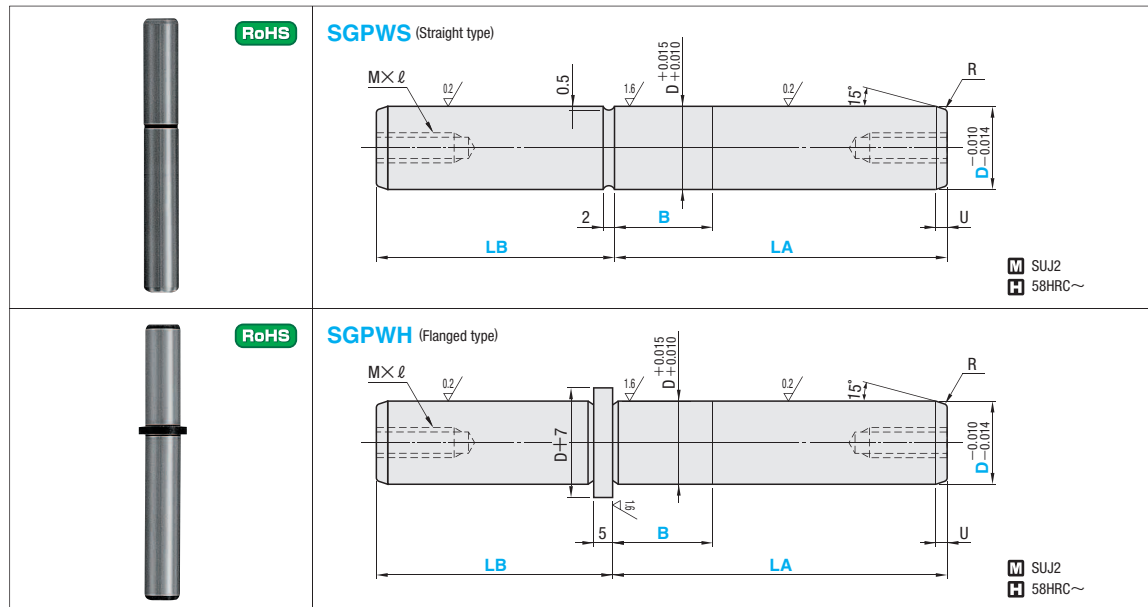

U	R	M×ℓ Pitch	Catalog No. Type	D	LA	LB 10mm increments	B 1mm increments	U/Price Q'ty : 1~9	
								SGPWS	SGPWH
2	1.5	M5×22 P0.8	SGPWH (Flanged type)	13	60	30~50	10~30	—	—
					70	30~60		—	—
					80	40~60		—	—
3	2	M6×25 P1.0	SGPWS (Straight type)	16	70	30~60	10~30	—	—
					80	30~70		—	—
					90	40~80		—	—
		20		80	40~70	—		—	
				90	40~70	—		—	
				100	50~80	—		—	
4	3	M8×25 P1.25	SGPWH (Flanged type)	25	90	50~70	10~30	—	—
					100	50~80		—	—
					110	60~90		—	—

D	D1	t	M	Catalog No. Type	S 1mm increments	U/Price Q'ty : 1~9
17.3	15	8.5	6	16*	10~20	
24	19	11	8	20*	11~25	
29	24	11	8	25	11~30	

PD (No.)	①Bolt CB				
	S				
13	M5×15	M5×20	M5×25	—	—
16	M6×15	M6×20	M6×25	—	—
20	M8×15	M8×20	M8×25	M8×30	—
25	M8×15	M8×20	M8×25	M8×30	M8×35

* Stock only available for SSTK 16-12, SSTK 16-15 and SSTK 20-15.

Order **Catalog No.** — **S**
SSTK 16 — 12

• Printed in Red • Printed in Blue
 Delivery **SGP Stock** **5** Days **Express A** **P.i**

For area out of Singapore please refer to P.i.

Quantity discount rate		
Quantity	1~9	10~20
Rate	—	5%

Use SSTK when setting a stripper guide bushing for ball cage to SGPWS and SGPWH.

Order **Catalog No.** — **LA** — **LB** — **B**
SGPWS 25 — 100 — 60 — B30

Delivery **5** Days
 For area out of Singapore please refer to P.i.

Quantity discount rate		
Quantity	1~9	10~20
Rate	—	5%

Alteration **Catalog No.** — **LA(LAC)** — **LB(LBC)** — **B** — **(TC·PC·NC)**
SGPWH 20 — LAC 78 — 50 — B25 — TC4

Alteration	Code	Spec.	Price
	LAC	Dimension LA alteration D LA 1mm increments 13 60 50≤LAC<60 70 61≤LAC<70 80 71≤LAC<80 70 60≤LAC<70 80 71≤LAC<80 90 81≤LAC<90 80 70≤LAC<80 20 90 81≤LAC<90 100 91≤LAC<100 90 80≤LAC<90 25 100 91≤LAC<100 110 101≤LAC<110 The tap depth becomes shorter by (LA-LAC).	Quotation
	TC	Changes flange thickness 3≤TC<5 1mm increments Applicable to SGPWH	Quotation
	PC	Adds groove for bolt fixing 1mm increments 5≤PC≤B-5 Applicable to SGPWS	Quotation

Alteration	Code	Spec.	Price
	LBC	Changes dimension LB D LA 1mm increments 13 60 20≤LBC<60 70 20≤LBC<60 80 30≤LBC<60 70 20≤LBC<60 80 20≤LBC<70 90 30≤LBC<80 80 30≤LBC<70 20 90 30≤LBC<70 100 40≤LBC<80 90 40≤LBC<70 25 100 40≤LBC<80 110 50≤LBC<90 The tap depth becomes shorter by (LB-LBC).	Quotation
	NC	Adds groove for bolt fixing Fixed at 10mm position (for M6) Applicable to SGPWH B≥16	Quotation

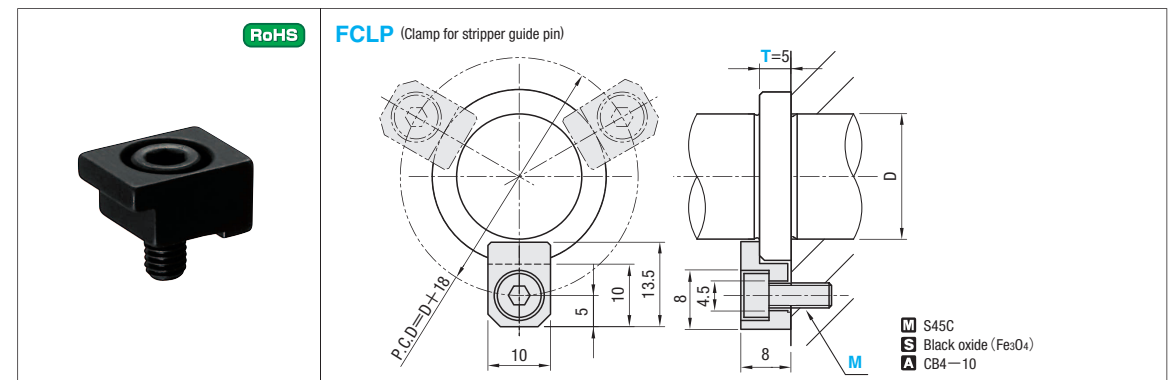

Catalog No. Type	T	M	U/Price (1Pc.)
			Q'ty : 1~9
FCLP	5	4	Quotation

Order **Catalog No.** — **M**
FCLP 5 — 4

Delivery **5** Days **Express A** **P.i**
 For area out of Singapore please refer to P.i.

Quantity discount rate		
Quantity	1~9	10~20
Rate	—	5%

FCLP can be used as a clamp for SGPWH, RSGPW and RSGPS. For D20 and below, use three clamps, and for D25 and above, use four clamps.